

# TREADWALL<sup>®</sup>

## **ALIGNMENT PROCEDURE WARRANTY REGISTRATION**

### **IMPORTANT NOTICE TO INSTALLERS:**

Warranty on TREADWALL installations will not become active until the procedures outlined in this booklet have been completed and the accompanying *Installation Warranty Registration* form has been completed, signed, and returned to Brewer's Ledge.

*Operating the TREADWALL without proper alignment will result in poor performance and damage to the machine.*

Brewer's Ledge will not be responsible for any installation-related problems unless these important steps are taken. Please take a few minutes to complete the alignment and send the *Installation Warranty Registration* in today.

**READ THIS BOOK BEFORE PUTTING ON THE LAST PANEL**

### **IMPORTANT INSTRUCTIONS:**

- 1. Complete the five alignment procedures.** There is one on each page.
- 2. Fill out the enclosed warranty registration form as you go through the alignment procedure.** When you are done, *sign and date the form.*
- 3. Send it back to Brewer's Ledge** in the enclosed envelope. This will activate the Installation Warranty.

*Keep this booklet with the Treadwall manual for future reference.*

# ***CONTENTS:***

1. FRAME ALIGNMENT
2. CHANNEL SPACING
3. PROXIMITY SWITCH ADJUSTMENT
4. ANGLE ADJUSTER CABLES
5. SETSCREWS
6. ADJUSTING MAIN CHAINS
7. ADJUSTING DRIVE CHAIN



**QUESTIONS?**

CALL :  
BREWER'S LEDGE INC.  
(800) 707-9616  
FAX (617) 983-5261

# 1.FRAME ALIGNMENT

**The frame must be vertical and parallel with the channels.** The frame is adjusted at the back with the two turnbuckles at the bottom of the x-braces.

**To check for parallel,** measure the distance from the inside of the right frame to the channel as shown in the diagram. This measurement should be 3 1/2".

**If the channel is more than 3 1/2" from the frame,** loosen the left turnbuckle and tighten the right.

**If the channel is less than 3 1/2" from the frame,** loosen the right turnbuckle and tighten the left.

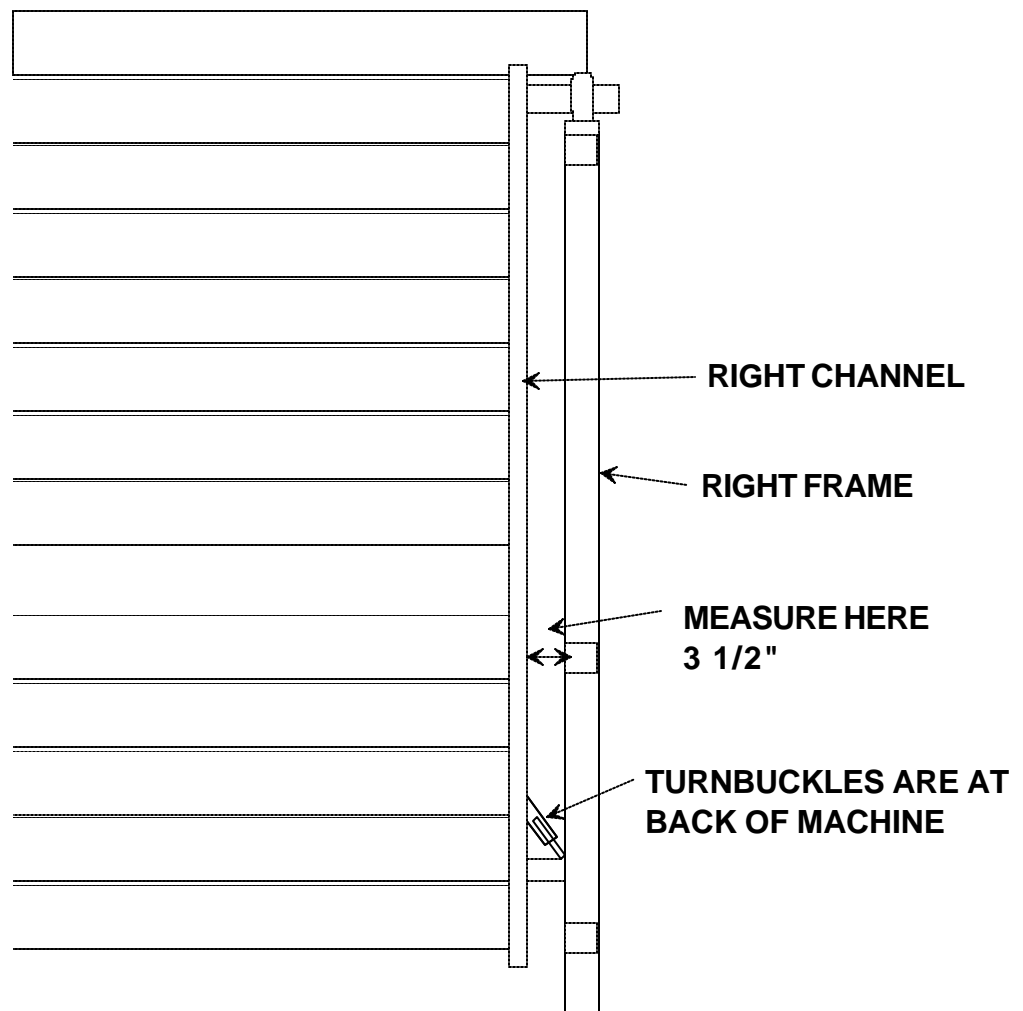

View from front of machine

## 2. CHANNEL SPACING

As the panels travel down the channels, there should be a clearance at each end of the panels to allow them to move freely.

The clearance at the top of the channels is set at the factory. Check this clearance. It should be about 3/16" at each side of the machine. If the panels are rubbing on one side at the top, adjustments can be made by loosening the setscrews on the large bearings at the top of the two channels and moving the channels back and forth with a prybar. Usually this will not be necessary.

The clearance at the bottom of the channels is adjusted with the two turnbuckles on the channel x-bracing. Adjust these two turnbuckles until the clearance is the same at each end of the bottom panel. *Do not overtighten* these turnbuckles. Only tighten them enough so that the wall cannot sway sideways - finger tight. Once adjusted, wire the turnbuckles so that they can't loosen.

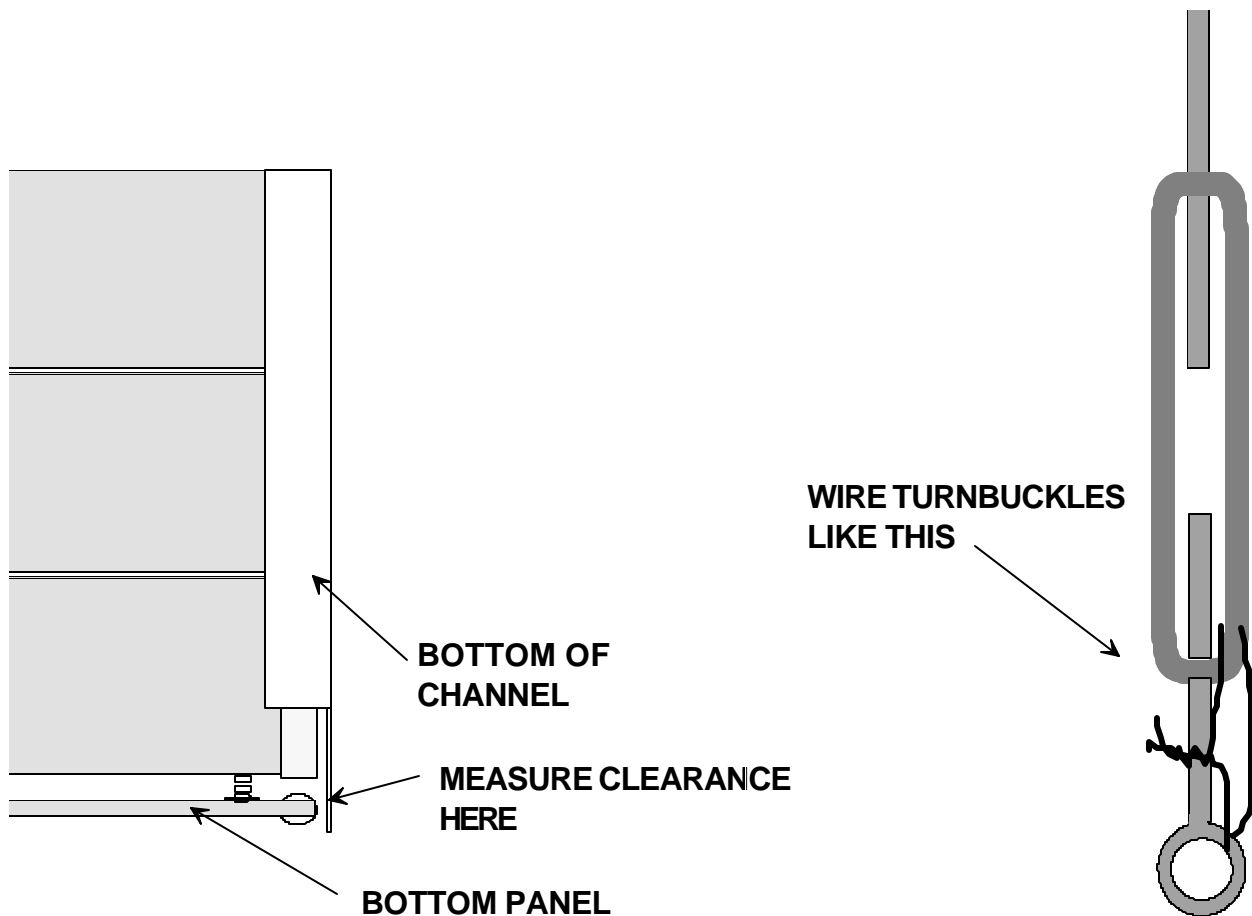

### 3. PROXIMITY SWITCH ADJUSTMENT

The proximity switch counts every second magnet, each count indicating 1 foot of distance. The switch breaks a tiny electrical current from the counter which causes a "count".

The magnets should pass within about 1/8" of the switch as shown below and in the install manual. Check the counter and make sure it is consistently counting 1 foot for every second magnet.

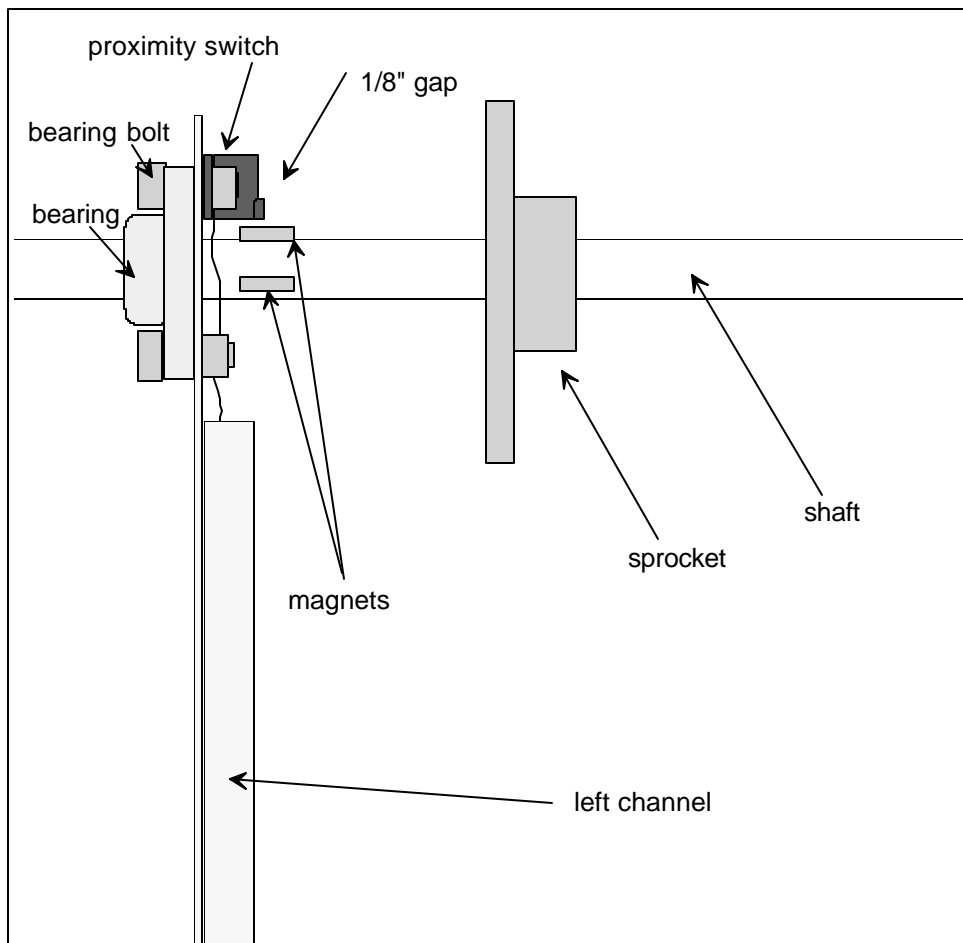

Panel Bar

## 4. ANGLE ADJUSTER CABLES

**If the angle adjuster cables are not properly installed, they can wear and break prematurely.** Also, if the bolts that hold them to the pipes are not installed, the channels will become mis-aligned to each other.

**Sight into the end of the adjuster pipe.** It should look like Fig. 1. Note that the cable loops down into the pipe, and the long 1/4" bolt goes through the kink and holds it in place.

Fig. 2 shows the cable wind from the top. (This is how it looks without the cable guard in place.) Note the direction of the wind - it is the same on both ends of the pipe.

**The winds should look like fig. 2** - they must be completely even and close together. If there are spaces, use a screwdriver and hammer to push the winds together.

**Lubricate the cables with silicon spray. Tighten the turnbuckle** on each cable and move the wall completely back and forth about 2 dozen times to stretch the cables. Grab the cables behind the pipe and push them hard back and forth to stretch them. If the cables stick up in the middle of the wind where they exit the hole in the pipe, hammer them down flat. Then re-tighten the cables and lock down the locking nuts so they won't loosen. *The cables should be re-tightened several times in the first two weeks of operation.*

***Do not operate the wall without the cable guards in place.***

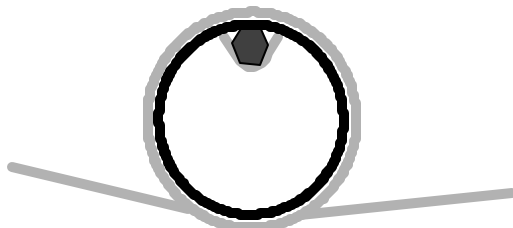

FIG. 1

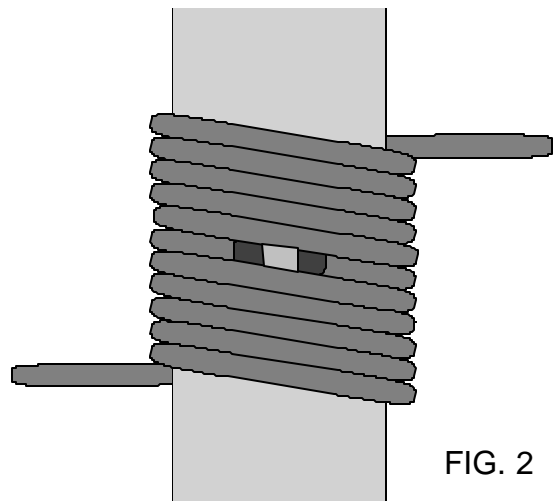

FIG. 2

## 5. SETSCREWS

There are several setscrews that must be tightened.

Tighten all setscrews:

- Main bearings (2 each - 4 total)
- Channel bearings (2 each - 4 total)
  
- Lower channel bearings (at the bottom of the channels) (2 each - 4 total)
- Drive sprockets (one on pump and one on main shaft) (2 each - 4 total)

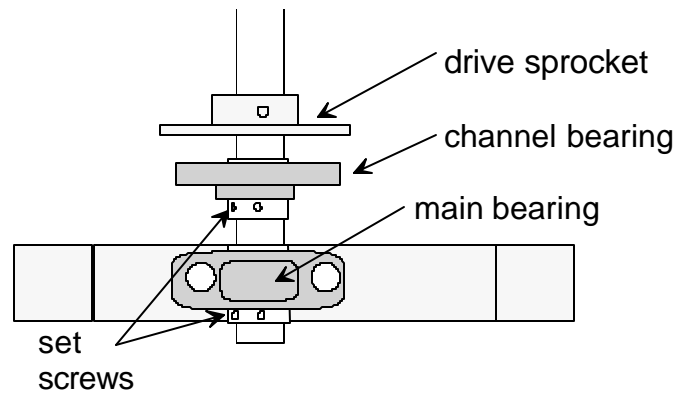

VIEW FROM TOP OF TREADWALL

## 6. MAIN CHAINS

The main chains must be adjusted after a few minutes of use

Push down the lower bearings on each channel with the tension adjuster bolt (1).

As you adjust the tension, wiggle the lowest panel as shown in the diagram (3). Look into the access hole (4) and watch where the chain meets the sprocket. When properly adjusted, the chain will still pull away slightly from the sprocket. If the chain is too tight, the Treadwall will operate sluggishly.

### Adjust both sides.

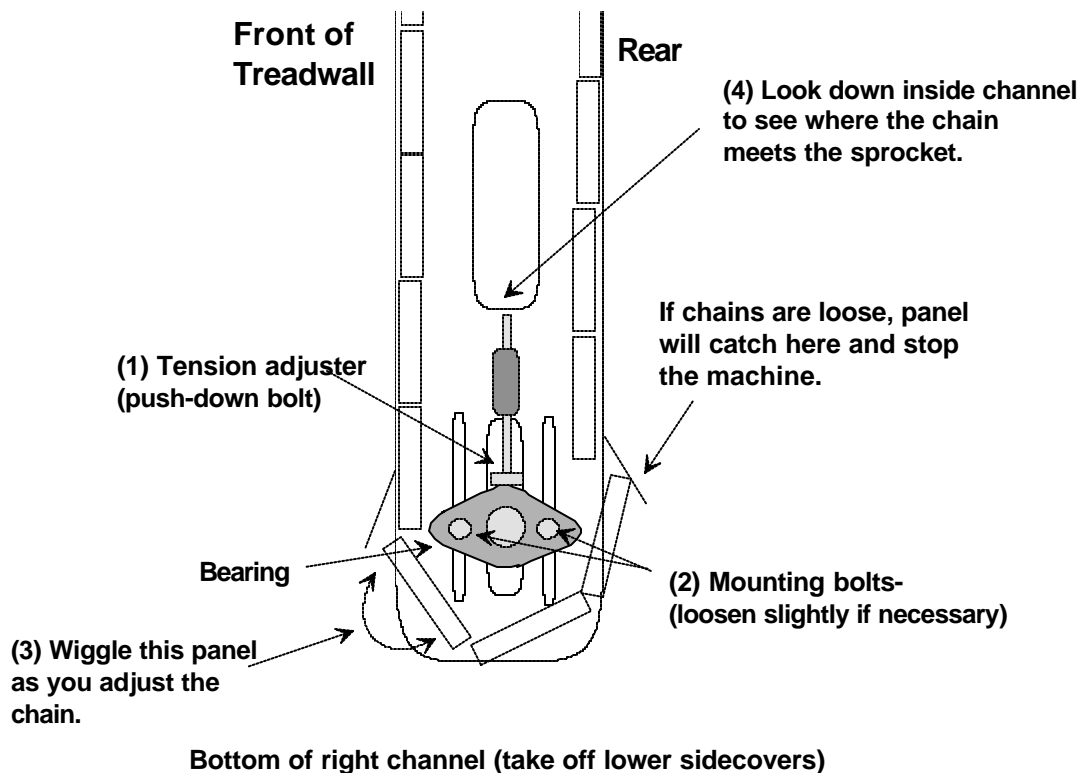

## 7 .Adjusting drive chain

The drive chain will have to be adjusted after a few minutes of use

Tension of the chain can be checked by feeling the chain through the access hole above the control panel. If it is loose, adjust it by pushing down the pump with the adjuster bolt. First loosen the hold-down bolt near the bottom of the panel.

Do not overtighten the drive chain. Take out the excess slack, but leave a little looseness in the chain or the Treadwall will move sluggishly.

If you make the chain too tight by mistake, loosen the adjuster bolt and loosen the chain by inserting the handle of a large crescent wrench into the access hole and prying the chain towards the center of the channel

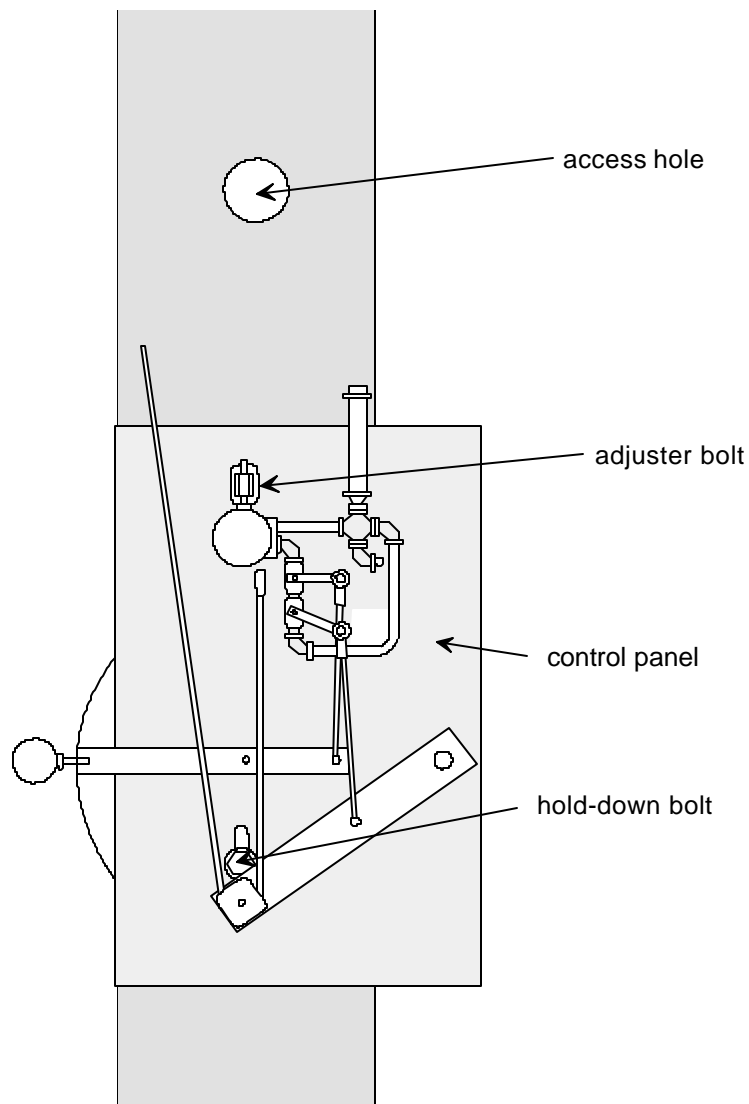

# INSTALLATION WARRANTY REGISTRATION

Please complete the following page and either return it by mail in the envelope provided or fax it directly to (617)-983-5261 24 hours a day, "Attn.,: Installation Department"

Please check each box indicating that the alignment procedure on the referenced page has been completed and fill in all the blanks. *These procedures are very important, and if any of them are neglected it can result in poor operation and broken parts.*

Date: \_\_\_\_\_ Owner's name: \_\_\_\_\_

Installer Name: \_\_\_\_\_ Serial number of Treadwall: \_\_\_\_\_

Installer telephone: \_\_\_\_\_

- (Page 1) The distance between the frame and the right channel has been adjusted and measures \_\_\_\_".
- (Page 2) At the bottom of the channels, the panels have the same clearance at each end. The clearance measures \_\_\_\_".
- (Page 2) The turnbuckles inside the channel have been wired closed.
- (Page 3) The Climbometer counts on every second magnet.
- (Page 4) The cables winds are even and closely spaced.
- (Page 4) The wall angle has been moved back and forth at least \_\_\_\_ times to stretch the cable.
- (Page 4) The cables have been fully tightened.
- (Page 4) The cables guards are installed.
- (Page 4) The maintenance staff has been informed to inspect and tighten the cables for \_\_\_\_ weeks.
- (Page 5) All setscrews have been tightened. The total number of setscrews tightened is \_\_\_\_
- (Page 6) The drive chain has been adjusted - all slack taken out, but not tight.

Signature of Installer: \_\_\_\_\_